

# Wernher von Braun's Space Plane

Although this spacecraft was never built and may seem odd by today's standards, half a century ago it represented the cutting edge in aerospace engineering. It was designed by one of the most famous rocket scientist of all time, Wernher von Braun. The craft was portrayed in magazine articles and books of the day inspiring many young people to pursue careers in the field of aerospace.

This concept dates from the early 1950's, years before the Soviet Union launched the first satellite into space. It is the third stage of a rocket that would have stood 265 feet tall and measured 65 feet in diameter. It's mission was to ferry people and cargo to Earth orbit. There, giant wheel-shaped space stations would be built and used to launch missions to the moon and planets.

To print this model you will need a computer printer and several sheets of letter or A4 size cover paper. I suggest 67# cover paper since heavier paper is difficult to wrap tightly enough to form some of the parts.

You will need a good pair of scissors and some white glue to build this model. I recommend a hobby knife and a straight-edge for cutting straight lines. In addition, using gray or black markers to color the edge of the paper will improve the look of the finished model. A soft pencil can be used instead of a gray marker. I used a silver marker to give the engines a metallic look.

## A paper model in 1/100 scale

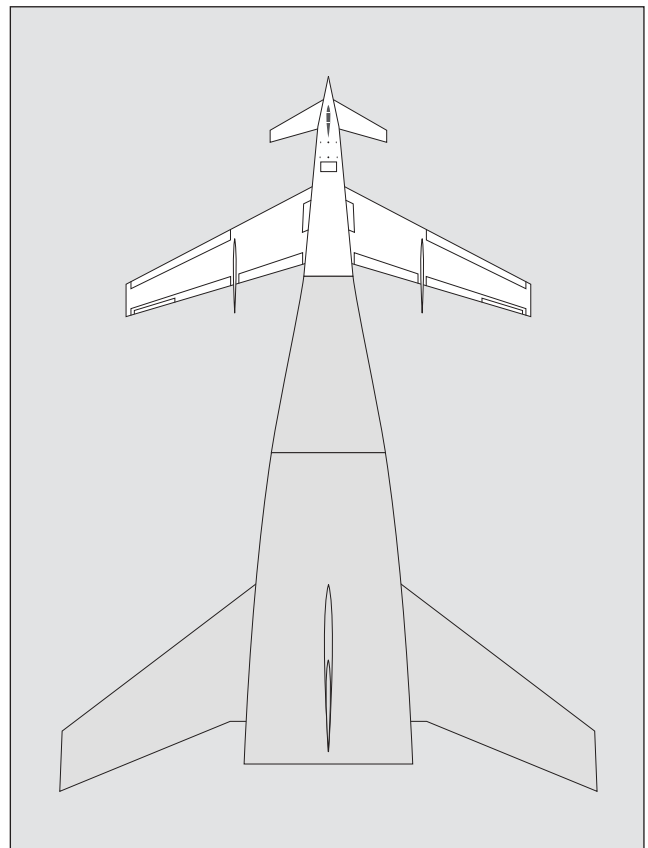

1. Cut out and discard the two triangles from part 1. Cut out parts 1, 1a, 1b, 1c (Optional: use a felt tip marker to color the edge of part 1 dark gray or black. Test the marker on the edge of scrap paper to insure it doesn't bleed into the paper. I use a Sharpie fine point).

Glue part 1a to part 1 along one of its straight edges. The heavy gray line on part 1a should face the same direction as the printing on part 1. Wrap one edge of part 1 around until it meets the other and glue to part 1a.-

Glue part 1b inside the small end of part 1. The tabs should project out from the opening. Glue part 1c inside part 1. A pencil with an eraser can be used to position the part in the narrow end of part 1. Glue may be inserted in the small opening with a toothpick or another small stick.

2. Cut out parts 2 and 2a (Optional: the edges of part 2 can be colored as part 1 was in step 1). Glue part 2a to part 2 along one of its straight edges. The heavy gray line on part 2a should face the same direction as the printing on part 2.

Wrap one edge of part 2 around until it meets the other and glue to part 2a. It will be difficult to wrap the pointed ends of these parts the full 360 degrees. A small dowel, a pen barrel, or a round pencil should be used to help wrap the parts appropriately.

3. Glue the part 2 assembly to the part 1 assembly. The seam on one assembly should line up with the seam on the other. This is the fuselage.

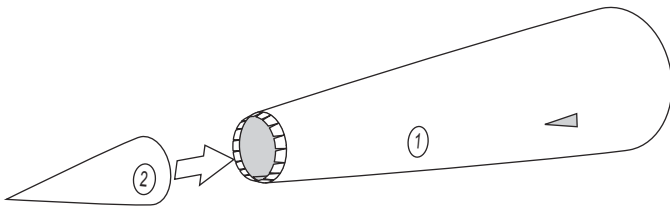

4. Cut out part 3 and fold on the dashed lines. Glue one narrow strip to the other forming a triangular girder. This is the wing spar. Set this aside.

5. Cut out and discard the two rectangles from part 4a. Cut out parts 4 and 4a. Fold part 4a on the dashed lines and glue the tabs to the corresponding areas on part 4a. Glue part 4 to the square side of 4a with the printed side facing away from 4a. Line up the four small marks on part 4 with the corners of 4a.

6. Insert the part 4 assembly into the fuselage making sure the rectangular holes in part 4 line up with the triangular holes in the fuselage. Insert part 3 (the wing spar) into one of the triangular holes in the fuselage. Center part 3 in the fuselage using the heavy lines on part 3 as a guide. Put a spot of glue

where the fuselage meets the wing spar on each side to affix the wing spar to the fuselage. Glue the part 4 assembly in the fuselage with a few small dabs of glue.

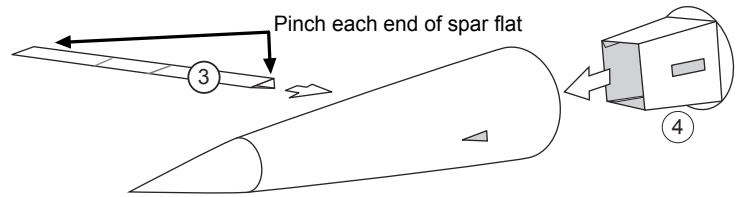

7. Cut out parts 5a, 5b, 5c, and 5d. Carefully bend 5a, 5b, and 5c 180 degrees as shown below. Glue parts 5d under 5a, 5b, and 5c. These parts will make the canopy. (Optional: the edges of part 6 can be colored as part 1 was in step 1). There is an extra set of parts in case your first attempts are less than perfect. Glue part 5c to the top of the fuselage where it is marked "canopy". Glue part 5b and then 5a to the fuselage.

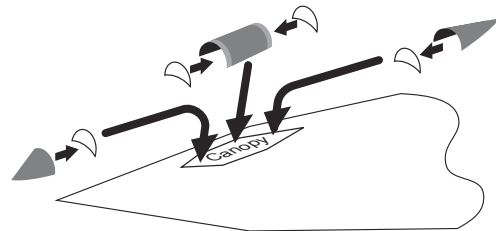

8. Cut out parts 6 and 6a. (Optional: the edges of part 6 can be colored as part 1 was in step 1). Fold over 6a and glue it closed. Glue 6a to the back of part 6 as shown below. Fold part 6 over and glue closed. Repeat with the other parts 6 and 6a.

These two finished parts are the forward wings (canards). Glue the canard wings to the sides of the forward fuselage on the black lines. They should line up with the wing spar.

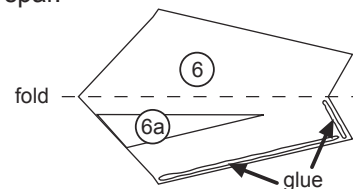

9. Cut out parts 7, 7a, and 7b. (Optional: the edges of part 7 can be colored as part 1 was in step 1). Fold over part 7 and glue at the trailing edge and wing tip as shown below. Glue only at the very edges.

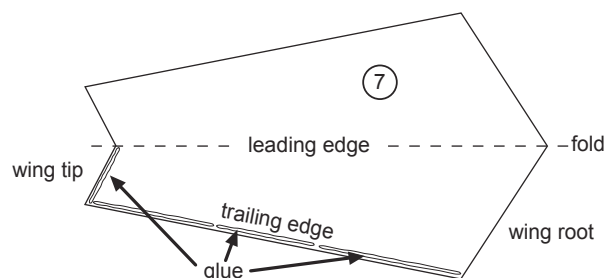

Fold over the tabs on parts 7a and 7b. Insert and glue part 7a at the leading edge of the wing root. Insert and glue part 7b at the trailing edge of the wing root. You may have to spread the trailing edge of part 7 where it was glued so that part 7b will fit. Use a knife for this. There should be a big gap between parts 7a and 7b after they are installed in part 7. This gap will accommodate the wing spar.

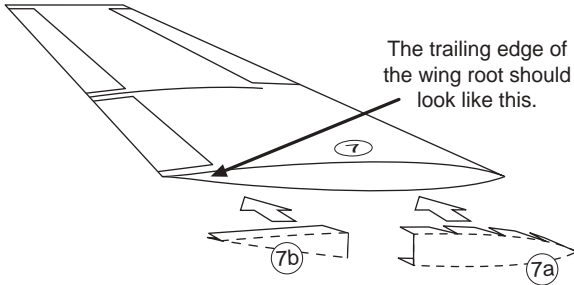

Repeat the above step with parts 8, 8a, and 8b. These two assemblies are the main wings. Glue each wing to the fuselage as shown. Note the method of identifying the top of each wing.

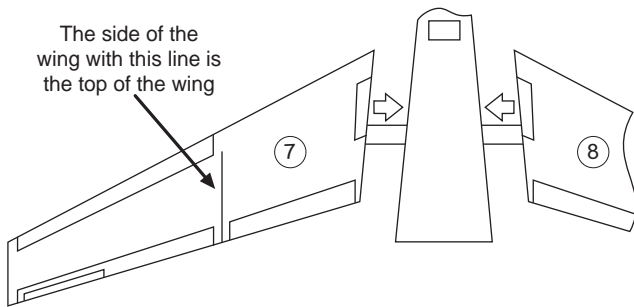

10. Cut out parts 9 and 9a (Optional: the edges of part 9 can be colored as part 1 was in step 1). Glue part 9a to part 9 as shown below. Fold over part 9 and glue. These are the vertical stabilizers.

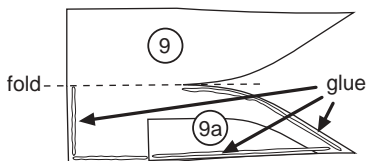

Glue the vertical stabilizers to the tops of the wings along the black line as shown.



11. Cut out part 10 and glue it inside the rear fuselage (Optional: use a gray felt tip marker or a soft

pencil to color the edge of part 10 gray). The printed side should face inward. It may be necessary to trim the edges to make it fit.

12. Cut out parts number 11, fold them in half and glue them closed (Optional: the edges of part 11 can be colored as part 10 was in step 11). You will need 12 of these (there are 2 extra). Glue these inside the rear fuselage with the narrow ends pointed forward and the cut edges glued to the white lines on part 10. It may be necessary to trim one end of each part so they will fit.

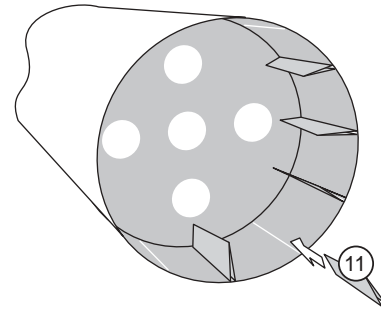

13. The remaining parts form the engines. (Optional: a black marker can be used to color the inside of the large cone. A silver marker can be used to color the outside of each engine).

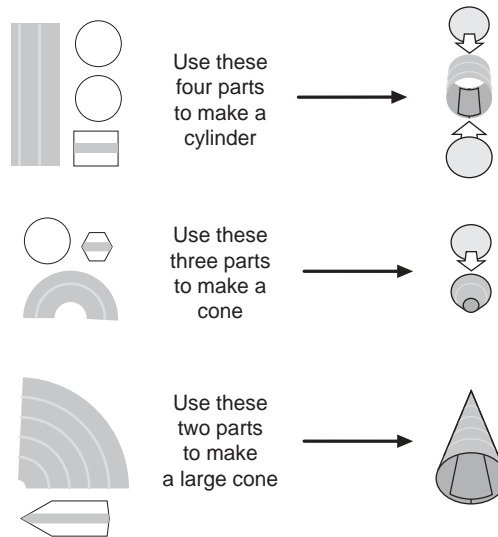

Glue the small cone to the cylinder and glue the point of the larger cone in the small hole of the small cone. You need five engines. Glue them to the white circles in the back of the fuselage. That's it. Your done.

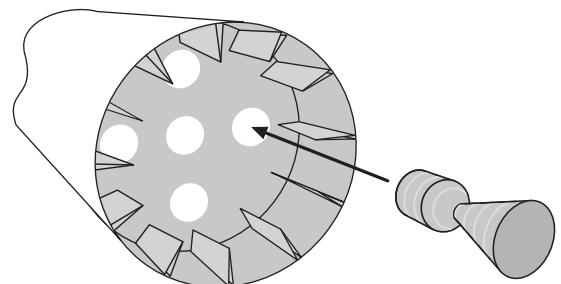

5A

5B

5C

5A

5B

5C



5D



5D

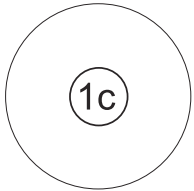

1c

1

1a

1b

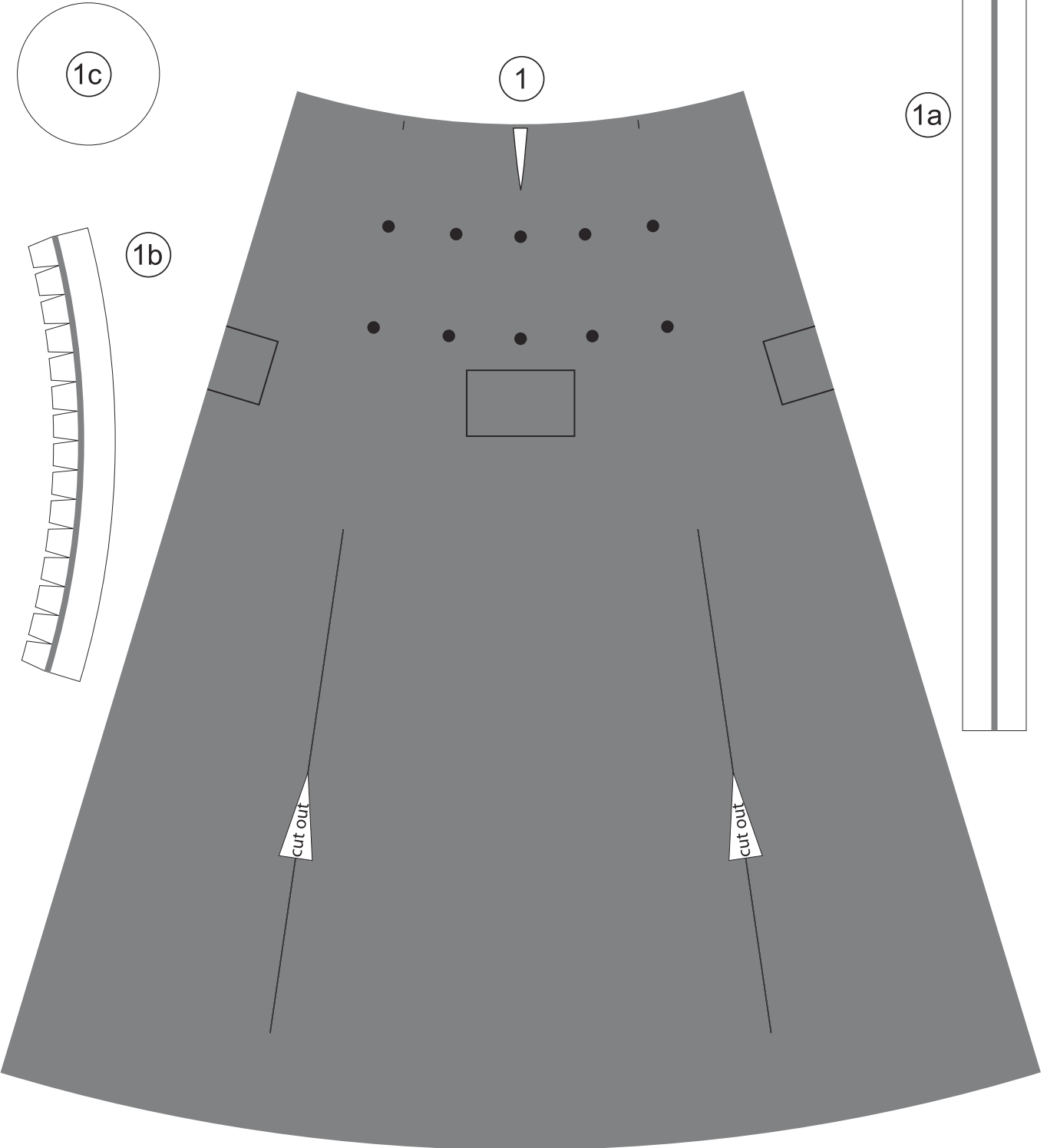

cut out

cut out

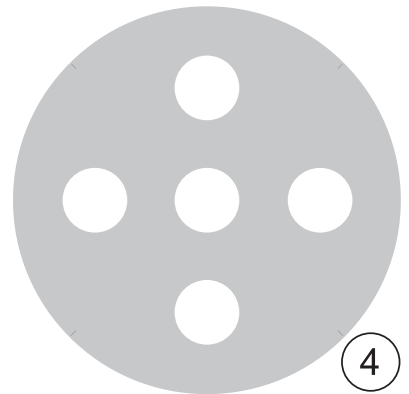
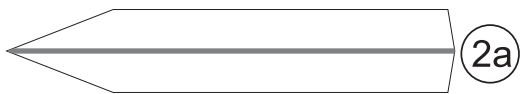
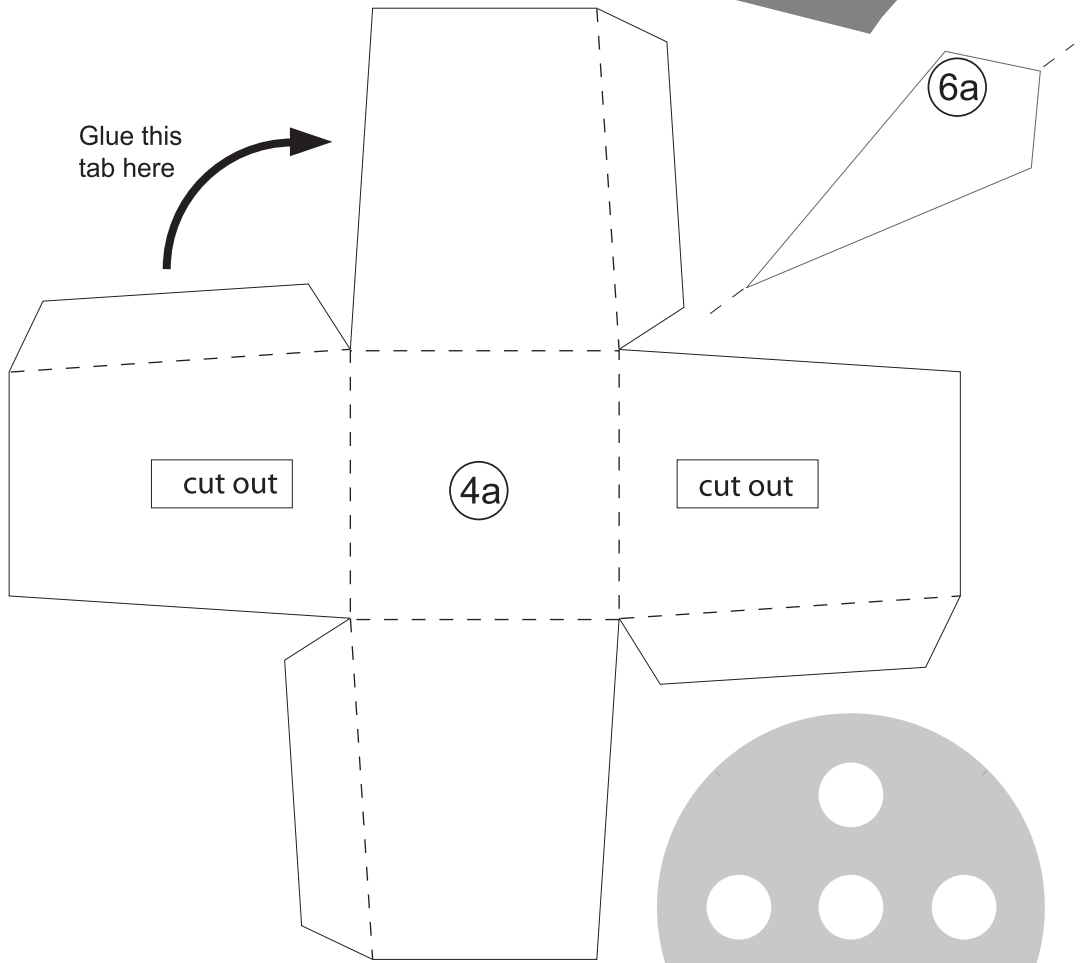
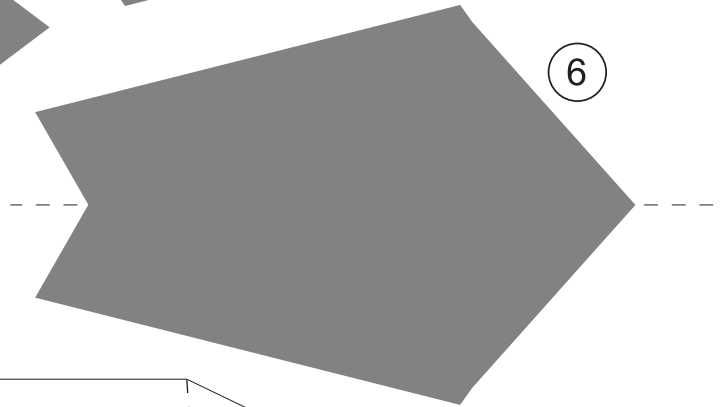
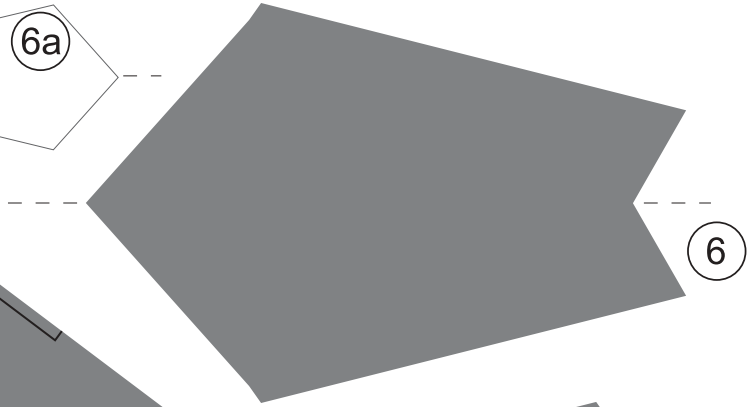
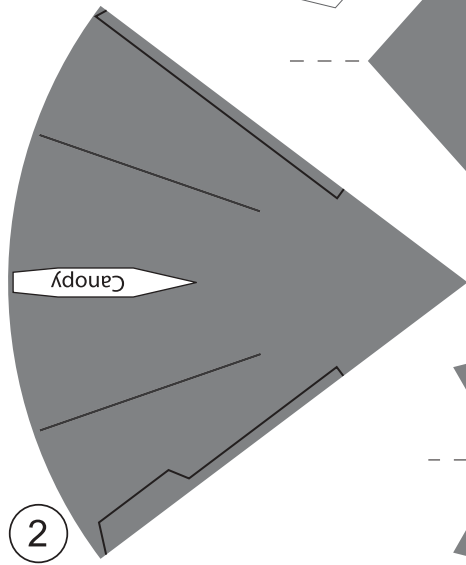
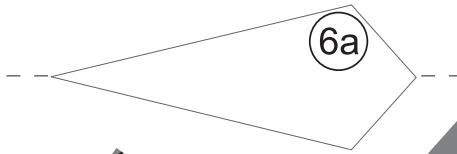
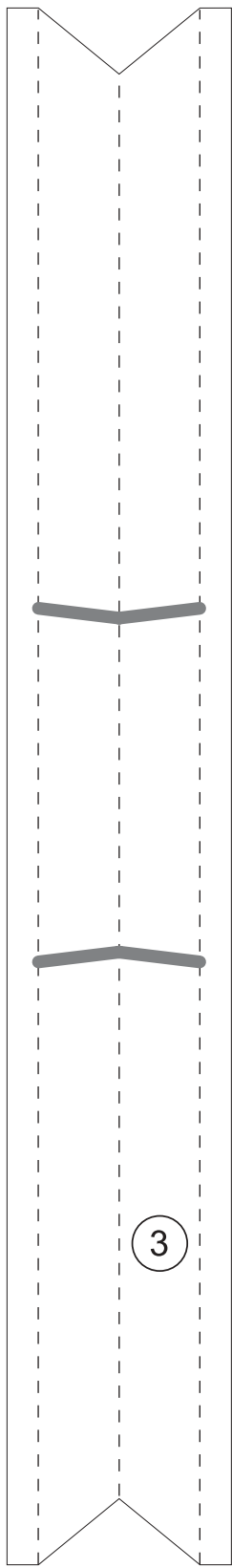

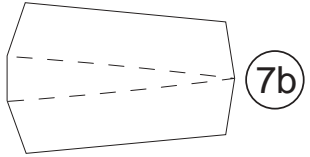
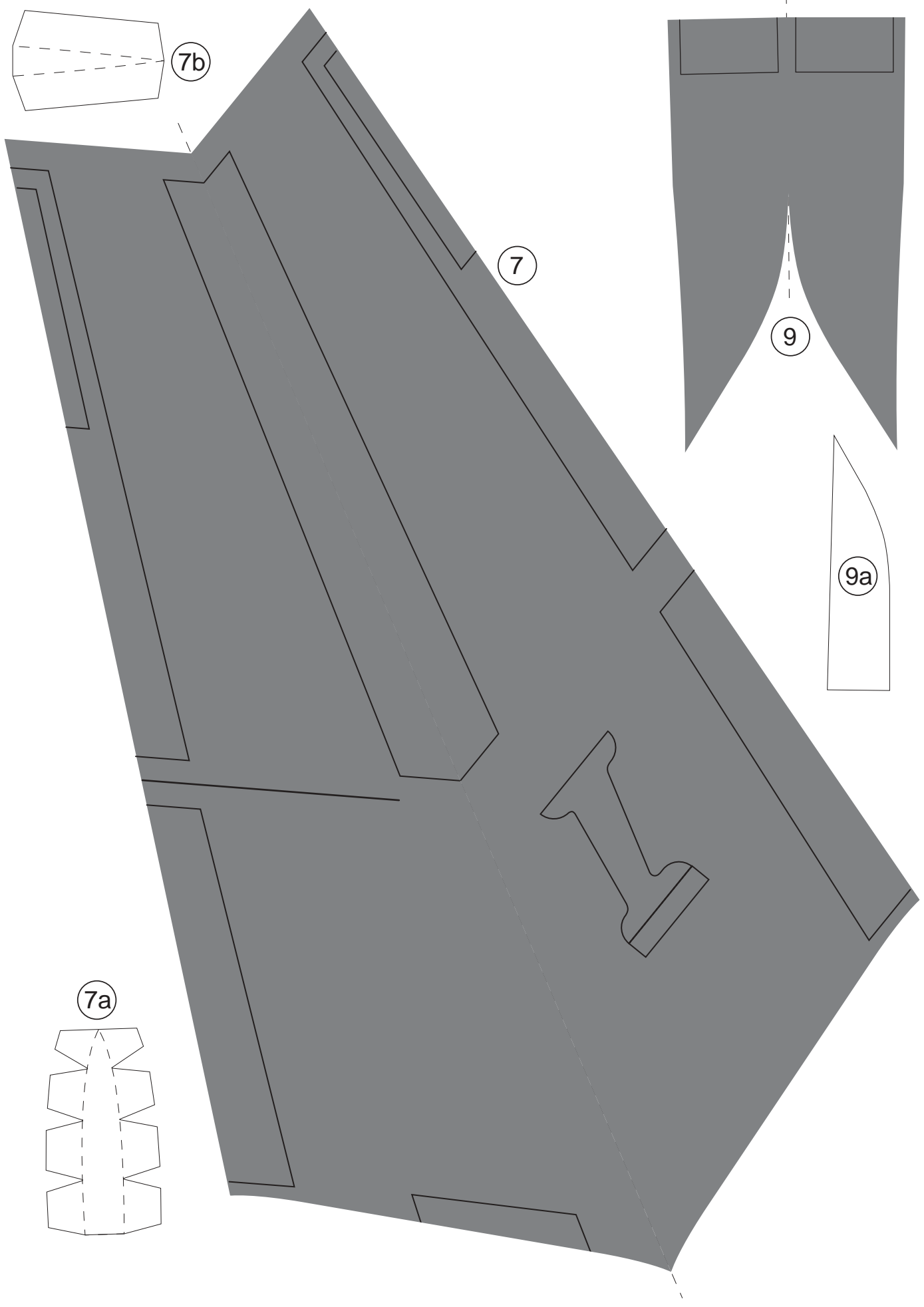

7b

7

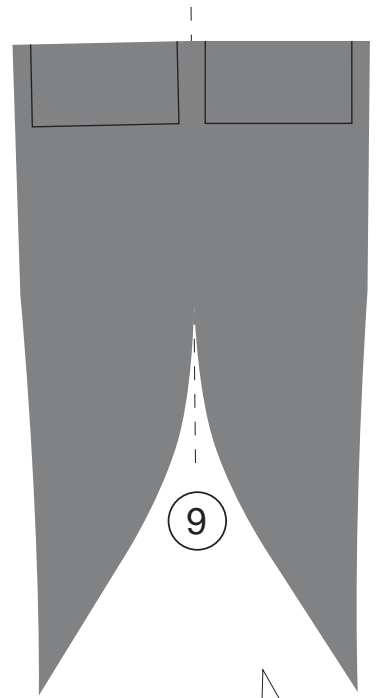

9

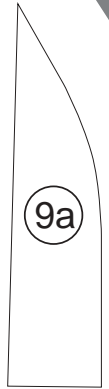

9a

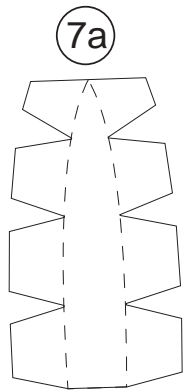

7a

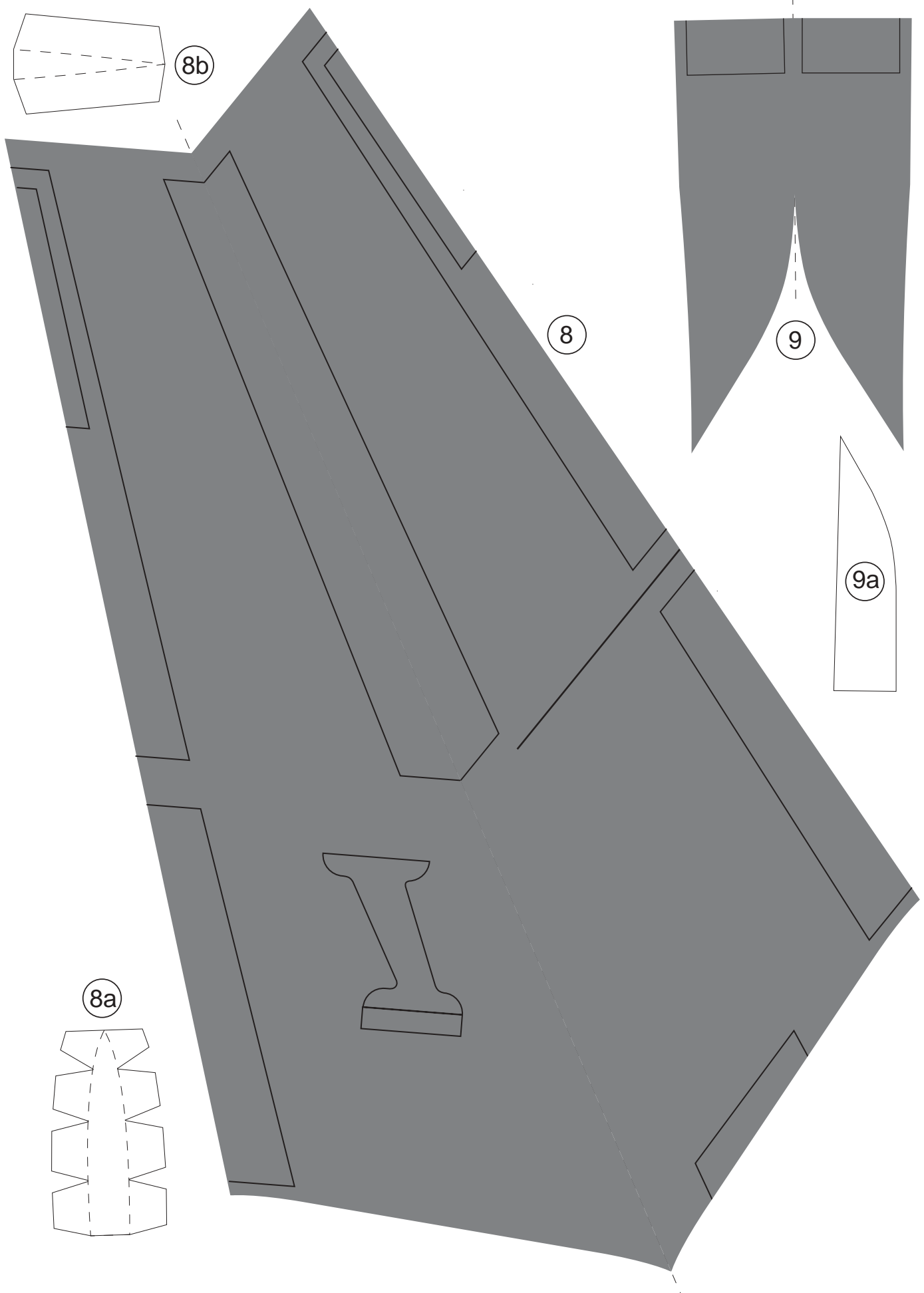

8b

8

9

9a

8a

